

HWBIG

Sollevamateriali in alluminio con portata massima di 250 Kg.
Aluminium material lift with a maximum capacity of 250 kg.



MANUALE / MANUAL



Selezionare da Configuratore
Select from configurator

Base bassa per entrare sotto le scaffalature
Low base to fit under the shelving

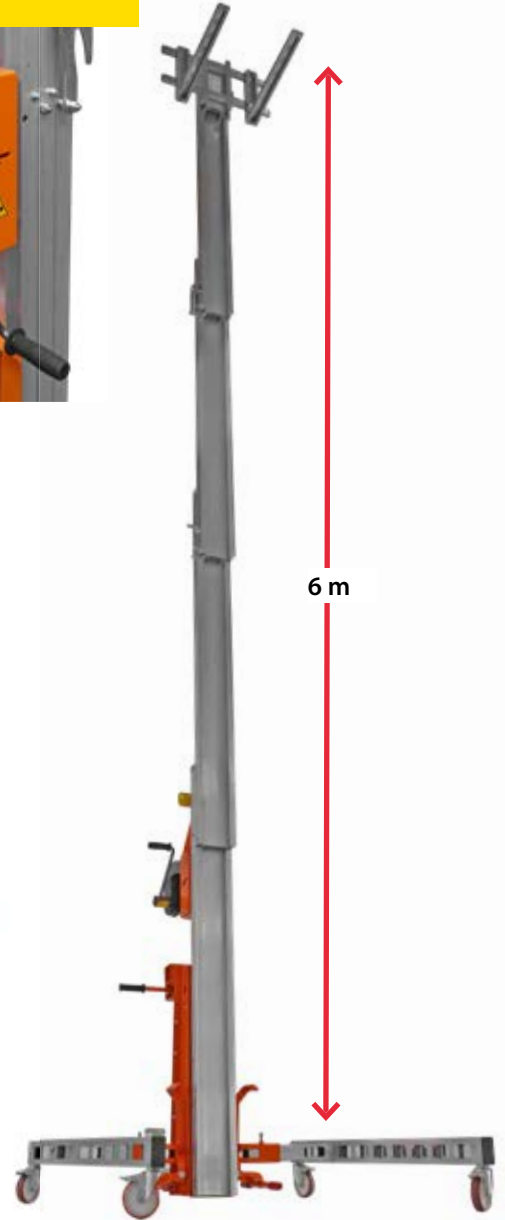

Specifiche tecniche / Technical specifications

ART. ITEM	PESO (kg) WEIGHT (kg)	PORTATA (kg) CAPACITY (kg)	A1 MAX (cm)	A2 MAX (cm)	B (cm)	C (cm)	D (cm)	E (cm)	F (cm)	G (cm)	H (cm)	I (cm)	ZAVORRE BALLAST
HWBIG1	95	250	150	195	70	194	70	100	197	135	62	194	1+1
HWBIG2	112	250	300	345	70	194	70	100	197	141	67	194	2+2
HWBIG3	144	200	450	495	70	199	74	133	192	182	-	199	2+2
HWBIG4	162	150	600	645	70	199	80	133	198	182	-	199	2+2

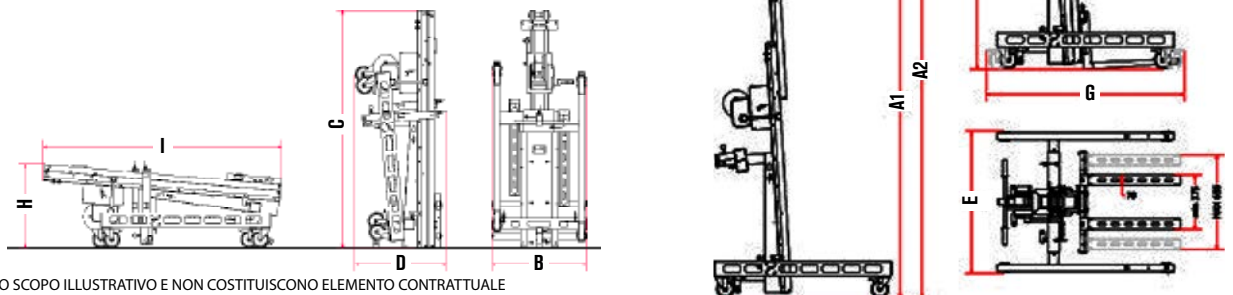

LE IMMAGINI SONO FORNITE AL SOLO SCOPO ILLUSTRATIVO E NON COSTITUISCONO ELEMENTO CONTRATTUALE
THE IMAGES ARE PROVIDED FOR ILLUSTRATIVE PURPOSES ONLY AND DO NOT REPRESENT A CONTRACTUAL ELEMENT



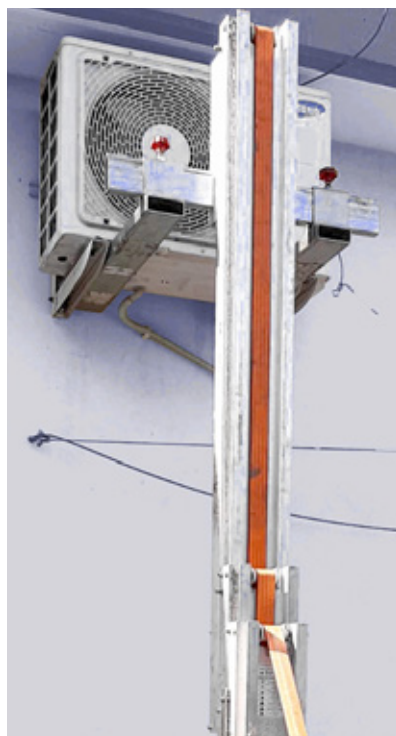

L'HW è completamente configurabile secondo le esigenze / The HW model is fully customizable according to your needs.

COMPONENTI / COMPONENTS

Vedi tutti i componenti disponibili sul configuratore.
See all available components in the configurator.

HW.KIT2Z - HW.KIT4Z - HW.KIT6Z



Kit zavorre HW composto da 2 supporti per la base e zavorre necessarie in base al modello di HW selezionato
HW ballast kit consisting of 2 base supports and the necessary ballasts based on the selected HW model.

HW.B



Piano con rulliere bidirezionali
Platform featuring two-way roller conveyors

HWI.1



Braccio oscillante per il prelievo di bobine. Interno tubo da 75 a 150 mm. Portata max 150kg.
Swinging arm for retrieving reels. Internal tube diameter from 75 to 150 mm. Maximum capacity of 150 kg.

HW.FR



Forche regolabili in larghezza con spessori per prelievo e posizionamento barriques.
Adjustable width forks with spacers for picking up and positioning barriques.

HWI.2



Tubo per prelievo bobine con estrattore elettrico, peso max estrazione 50 Kg.
Reel lifting tube with electric extractor, maximum extraction weight 50 kg.

HW09



Speciale base bassa per accesso facile/pallet.
Special low base for easy access to pallets.

HW.BR



Braccio per blocco bobine azionabile dal basso.
Reel blocking arm operable from below.

HW.RU



Forche con rullo
Forks with roller.

HW.S4



Kit ventose con supporto orientabile per il sollevamento del vetro.
Suction cup kit with adjustable support for lifting glass.



CONFIGURA IL TUO SOLLEVAMATERIALE
CONFIGURE YOUR HW MATERIAL
HW CONFIGURATOR
www.faraone.com