

112/A

Attrezzature speciali per manutenzione automezzi.
Special equipment for vehicle maintenance.

112/A FOR
VEHICLES



Supera il test antiribaltamento laterale.
It passes the lateral overturning test.



Specifiche tecniche / Technical specifications

ART. ITEM	N° GRADINI N° OF RUNGS	ALTEZZA MINIMA (A)	ALTEZZA MASSIMA (B)	LUNGHEZZA BASE (C)
112/A6	6+6	220	325	175
112/A7	7+7	247	352	175
112/A8	8+8	273	377	175
112/A9	9+9	300	405	200
112/A10	10+10	326	431	200
112/A11	11+11	353	485	200

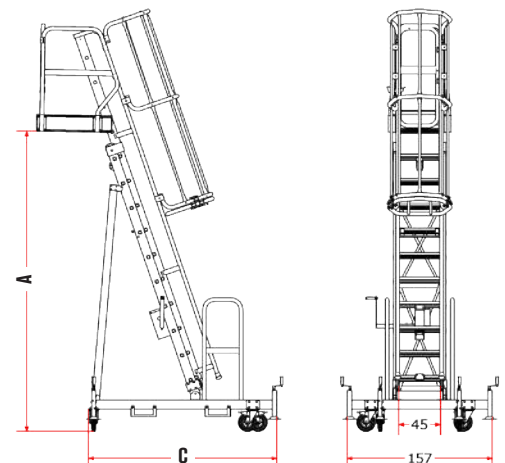
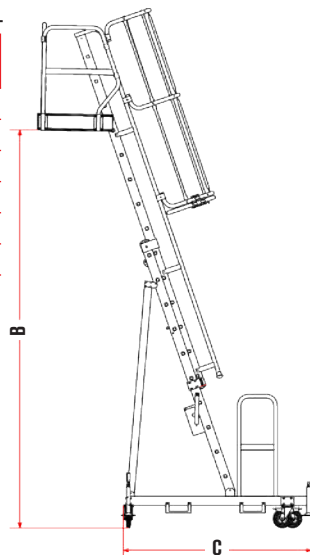

“Conformi alle norme EN 131.7 e EN 14122. Alcune configurazioni, se pur superando i test di stabilità richiesti dalle norme europee EN131.7 e EN 14122, per aspetti dimensionali o tecnici possono risultare non conformi a tali norme.”
“Compliant with EN 131.7 and EN 14122 Standards. Some configurations, even if passing the stability tests required by European standards EN 131.7 and EN 14122, may not comply with these standards in terms of dimensional or technical aspects.”

certificate



SU OGNI PRODOTTO VENGONO RIPORTATE LE INFORMAZIONI RICHIESTE DAL D.L. 81 ALLEGATO XX
THE INFORMATION REQUESTED BY L.D. 81 ART. XX ARE AVAILABLE ON EACH PRODUCT

LE IMMAGINI SONO FORNITE AL SOLO SCOPO ILLUSTRATIVO E NON COSTITUISCONO ELEMENTO CONTRATTUALE
THE IMAGES ARE PROVIDED FOR ILLUSTRATIVE PURPOSES ONLY AND DO NOT REPRESENT A CONTRACTUAL ELEMENT



**OFFERTE
SU RICHIESTA.
QUOTATIONS
UPON REQUEST
T. 0861.77221**

MISURE INDICATE IN CM. / SIZE IN CM.

Altre altezze realizzabili su richiesta. / Other heights are available on request.



ART. 112.PP

certificate

SU OGNI PRODOTTO VENGONO RIPORTATE LE INFORMAZIONI RICHIESTE DAL D.L. 81 ALLEGATO XX
THE INFORMATION REQUESTED BY L.D. 81 ART. XX ARE AVAILABLE ON EACH PRODUCT

LE IMMAGINI SONO FORNITE AL SOLO SCOPO ILLUSTRATIVO E NON COSTITUISCONO ELEMENTO CONTRATTUALE
THE IMAGES ARE PROVIDED FOR ILLUSTRATIVE PURPOSES ONLY AND DO NOT REPRESENT A CONTRACTUAL ELEMENT

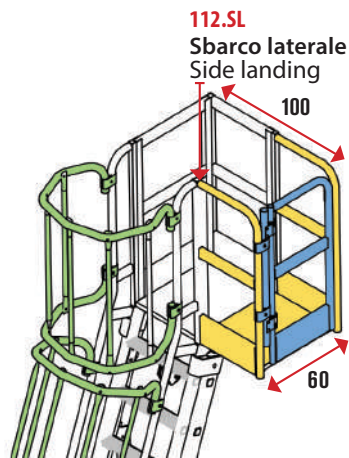

Progettata per garantire la massima sicurezza per la manutenzione in quota di automezzi di grosse dimensioni con altezze variabili.

- Sicura in ogni situazione grazie alla zavorra sistemata alla base e piedini regolabili;
- Versatile e facile da spostare (Completamente in alluminio);
- Altezza regolabile telescopicamente;
- Gabbia di protezione a 360°.

Designed to ensure maximum safety for maintenance at height on large vehicles with variable heights:

- Secure in every situation with base ballast and adjustable feet;
- Versatile and easy to relocate (fully aluminum);
- Telescopic height adjustment;
- 360° protective cage.

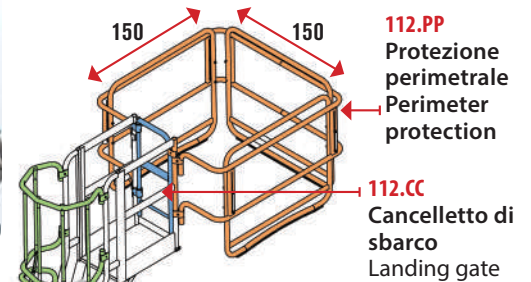

“Conformi alle norme EN 131.7 e EN 14122. Alcune configurazioni, se pur superando i test di stabilità richiesti dalle norme europee EN131.7 e EN 14122, per aspetti dimensionali o tecnici possono risultare non conformi a tali norme.”

“Compliant with EN 131.7 and EN 14122 Standards. Some configurations, even if passing the stability tests required by European standards EN 131.7 and EN 14122, may not comply with these standards in terms of dimensional or technical aspects.”